



## BRANZ Appraised

Appraisal No. 761 [2023]

## SIMPLEFIX WATER STORAGE CYLINDER RESTRAINT KITS

### Appraisal No. 761 [2023]

This Appraisal replaces BRANZ Appraisal No. 761 [2017]

Amended 05 September 2024

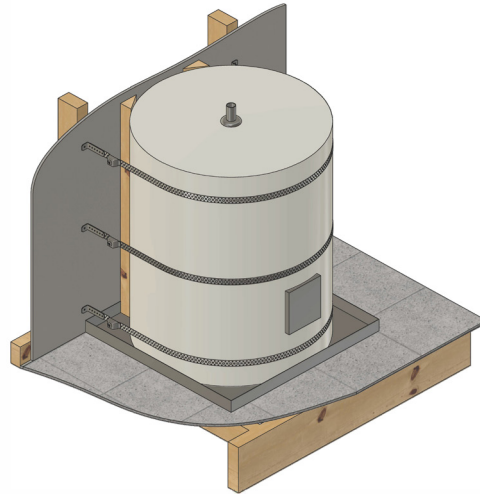

### BRANZ Appraisals

Technical Assessments of products for building and construction.



### Ray Staiger Limited

44 Hounsell Road

Burbush

Hamilton 3200

Tel: 07 850 4200

Fax: 07 850 4204

Web: [www.simplefix.co.nz](http://www.simplefix.co.nz)



### BRANZ

#### BRANZ

1222 Moonshine Rd,

RD1, Porirua 5381

Private Bag 50 908

Porirua 5240,

New Zealand

Tel: 04 237 1170

[branz.co.nz](http://branz.co.nz)



## Product

- 1.1 The SimpleFix and SimpleFix Stainless Cylinder Restraint Kits are for seismically restraining water storage cylinders.

## Scope

- 2.1 The SimpleFix and SimpleFix Stainless Cylinder Restraint Kits are used for seismically restraining water storage cylinders up to 700 litres.
- 2.2 The SimpleFix Cylinder Restraint Kits are for use with timber-framed buildings in dry interior environments.
- 2.3 The SimpleFix Stainless Cylinder Restraint Kits are for use with timber-framed buildings in dry interior or in external environments.

## Building Regulations

### New Zealand Building Code [NZBC]

- 3.1 In the opinion of BRANZ, the SimpleFix and SimpleFix Stainless Cylinder Restraint Kits, if designed, used, installed and maintained in accordance with the statements and conditions of this Appraisal, will meet the following provisions of the NZBC:

**Clause B1 STRUCTURE:** Performance B1.3.1, B1.3.2 and B1.3.4. The SimpleFix and SimpleFix Stainless Cylinder Restraint Kits meet the requirements for loads arising from earthquake [i.e. B1.3.3 [f]]. See Paragraphs 8.1 and 8.2.

**Clause B2 DURABILITY:** Performance B2.3.1 [b] 15 years. The SimpleFix and SimpleFix Stainless Cylinder Restraint Kits meet this requirement. See Paragraphs 9.1 and 9.2.

**Clause F2 HAZARDOUS BUILDING MATERIALS:** Performance F2.3.1. The SimpleFix and SimpleFix Stainless Cylinder Restraint Kits meet this requirement.



## Technical Specification

- 4.1 The SimpleFix Cylinder Restraint Kit components and accessories supplied by Ray Staiger Limited are:
- Galvanised strap, 25 x 0.75 mm, G550 [powder-coated options also available].
  - Galvanised earthquake brackets.
  - Tensioning device.
  - Type 17 screws, 55 mm long.
  - M5 bolts and nuts for connecting the straps to the earthquake brackets.
- 4.2 The SimpleFix Stainless Cylinder Restraint Kit components and accessories supplied by Ray Staiger Limited are:
- Grade 304 stainless steel strap, 25 x 0.70 mm, G550.
  - Grade 304 stainless steel earthquake brackets.
  - Grade 304 stainless steel tensioning device.
  - Grade 304 stainless steel type 17 screws, 55 mm long.
  - Grade 304 stainless steel M5 bolts and nuts for connecting the straps and the earthquake brackets.

## Handling and Storage

- 5.1 The SimpleFix Cylinder Restraint Kits are reasonably robust, but must be kept dry before and after installation. The SimpleFix Stainless Cylinder Restraint Kits should be kept dry before installation.

## Technical Literature

- 6.1 This Appraisal must be read in conjunction with:
- SimpleFix securing instructions for hot water storage cylinders up to 700 litres, supplied during installation.
- 6.2 All aspects of design, use, installation and maintenance contained in the Technical Literature and within the scope of this Appraisal must be followed.

## Design Information

- 7.1 SimpleFix Cylinder Restraint Kits are for use in dry, internal environments. The galvanised strap is optionally available powder-coated white and other selected colours. SimpleFix Stainless Cylinder Restraint Kits are for use in interior or exterior environments.
- 7.2 For water storage cylinders up to 360 litres capacity, the SimpleFix and SimpleFix Stainless Cylinder Restraint Kits are an Acceptable Solution in accordance with NZBC Acceptable Solution G12/AS1 Paragraph 6.11.4. For cylinders over 360 litres capacity, the SimpleFix and SimpleFix Stainless Cylinder Restraint Kits are an Alternative Solution to the NZBC and at the design stage of the timber wall framing, consideration should be given as to how earthquake loads will be transferred from the studs to the top and bottom plates.
- 7.3 Floor framing, flooring and platforms must be designed to support the water storage cylinder.

## Structure

- 8.1 The number of straps required when using the SimpleFix and SimpleFix Stainless Cylinder Restraint Kits depends on the size of the cylinder to be restrained and the height of the cylinder within the building. Table 1 below gives the number of straps to be used.
- 8.2 When the cylinder is to be installed more than 12 m above the ground, an additional strap is required to the number given in Table 1.

**Table 1: Cylinder Strap Requirements**

Cylinder Size	Number of Straps Required
Up to 200 litre capacity	Up to 3
201 litre up to 360 litre capacity	Up to 4
361 litre up to 500 litre capacity	4
501 litre up to 600 litre capacity	5
601 litre up to 700 litre capacity	6

## Durability

### Serviceable Life

- 9.1 The components of SimpleFix Cylinder Restraint Kits are all steel. As long as they are kept dry in service they are expected to have the same serviceable life as the cylinders that they restrain.
- 9.2 The components of SimpleFix Stainless Cylinder Restraint Kits are all Grade 304 stainless steel. They are expected to have the same serviceable life as the cylinders that they restrain.

## Maintenance

- 10.1 The SimpleFix Cylinder Restraint Kits will require little maintenance as long as they are kept dry. Any damaged straps or fixings must be replaced.
- 10.2 The SimpleFix Stainless Cylinder Restraint Kits will require little maintenance. Any damaged straps or fixings must be replaced.

## Installation Information

### Installation Skill Level Requirement

- 11.1 All design and building work must be carried out in accordance with the SimpleFix Cylinder Restraint Kits Technical Literature and this Appraisal. All building work must be undertaken by competent and experienced tradespersons conversant with the SimpleFix Cylinder Restraint Kits.

### SimpleFix Cylinder Restraint Kits Installation

- 12.1 Timber vertical blocking as described in NZBC Acceptable Solution G12/AS1 Paragraph 6.11.4 and Figure 14 must be installed. For external installations, suitably treated timber and fixings must be used. Additional timber framing may be required in retrofit situations to ensure adequate strap fixing is available. Separation between any treated timber and the water cylinder may be necessary.
- 12.2 SimpleFix and SimpleFix Stainless Cylinder Restraint Kits are installed in accordance with the Technical Literature. The earthquake brackets are screwed to the framing using the supplied screws. A suitable length of strap is then cut from the supplied reel. This is fixed to the earthquake brackets with the M5 bolts and nuts. The tensioner is then used to take up the slack in the strap.
- 12.3 Straps must not be installed where they clash with the water heater inlet, outlet or controls. Where the 100 mm maximum strap clearance from the top or bottom of the cylinder cannot be achieved, straps may be placed within the top and bottom 25% and one or two additional straps may be required. 1 additional strap placed centrally for water heaters up to 200 litres and 2 additional evenly spaced straps for cylinders 200-360 litres.
- 12.4 An additional centre strap is required where a storage water heater is located more than 12 m off the ground. This is additional to the numbers stated in Table 1 above.
- 12.5 A maximum total of four straps are required when complying with both 12.3 and 12.4.



## Basis of Appraisal

The following is a summary of the technical investigations carried out:

### Tests

13.1 Tensile tests were carried out to determine the strength of the system. These have been reviewed by BRANZ and found to be satisfactory.

### Investigations

14.1 Structural calculations have been carried out. These have been reviewed by BRANZ and found to be satisfactory.

### Quality

15.1 Details of the quality and composition of the materials used were obtained by BRANZ and found to be satisfactory.

15.2 Ray Staiger Limited is responsible for the quality of the product supplied.

15.3 The quality of installation, in accordance with the instructions of Ray Staiger Limited, is the responsibility of the installer.

## Sources of Information

- Ministry of Business, Innovation and Employment Record of amendments - Acceptable Solutions, Verification Methods and handbooks.
- The Building Regulations 1992.

## Amendments

### Amendment No. 1, dated 05 September 2024

This Appraisal has been amended to update Appraisal graphics, Table 1 and installation details.



**BRANZ Appraised**  
Appraisal No. 761 (2023)

**BRANZ Appraisal**  
Appraisal No. 761 (2023)  
14 September 2023

SIMPLEFIX WATER STORAGE  
CYLINDER RESTRAINT KITS



In the opinion of BRANZ, **SimpleFix Water Storage Cylinder Restraint Kits** are fit for purpose and will comply with the Building Code to the extent specified in this Appraisal provided they are used, designed, installed and maintained as set out in this Appraisal.

The Appraisal is issued only to **Ray Staiger Limited**, and is valid until further notice, subject to the Conditions of Appraisal.

### Conditions of Appraisal

1. This Appraisal:
  - a) relates only to the product as described herein;
  - b) must be read, considered and used in full together with the Technical Literature;
  - c) does not address any Legislation, Regulations, Codes or Standards, not specifically named herein;
  - d) is copyright of BRANZ.
2. **Ray Staiger Limited:**
  - a) continues to have the product reviewed by BRANZ;
  - b) shall notify BRANZ of any changes in product specification or quality assurance measures prior to the product being marketed;
  - c) abides by the BRANZ Appraisals Services Terms and Conditions;
  - d) warrants that the product and the manufacturing process for the product are maintained at or above the standards, levels and quality assessed and found satisfactory by BRANZ pursuant to BRANZ's Appraisal of the product.
3. BRANZ makes no representation or warranty as to:
  - a) the nature of individual examples of, batches of, or individual installations of the product, including methods and quality of work;
  - b) the presence or absence of any patent or similar rights subsisting in the product or any other product;
  - c) any guarantee or warranty offered by **Ray Staiger Limited**.
4. Any reference in this Appraisal to any other publication shall be read as a reference to the version of the publication specified in this Appraisal.
5. BRANZ provides no certification, guarantee, indemnity or warranty, to **Ray Staiger Limited** or any third party.

---

**For BRANZ**

**Claire Falck**

Chief Executive

Date of Issue:

14 September 2023