

## **PRODUCER STATEMENT – PS1 – DESIGN**

This Design Producer Statement (PS1) is issued by NZ Civil Structure Ltd to Ray Staiger Limited to inform the users of the use and installation method of the following fixings for both structural applications and durability as required by the New Zealand Building Code Clauses B1 & B2 respectively.

We have been engaged by Ray Staiger Limited to provide Design services for the following products in respect of the requirements of Clause B1 of the Building Code for Part only of the proposed building work. The design carried out by us has been prepared in accordance with: Compliance Documents issued by the Ministry of Business, Innovation & Employment: B1/VM1.

### **PRODUCT CODE AND DESCRIPTION**

The product code covered under this Producer statement are following.

#### **FFTP = SimpleFix Frame Fix & Top Plate Stiffener**

### **PRODUCT DESCRIPTION**

The FFTP is manufactured from Z275 1.6mm thick galvanised steel. Each FFTP is 240mm long x 88mm wide 'U' channel with 35mm folded up-stands along the longer length, with a further 10mm inward fold on the upstands. The FFTP is pre-punched with 62mm diameter hole and 10 x 6.3mm screw holes.

### **PRODUCT APPLICATION**

The FFTP is intended to reinstate the structural integrity of both 90 x 45mm and 140 x 45mm wall frame studs and top plates (including a top plate packer if used) that have a service hole of no greater than 60mm diameter drilled through its centre.

### **INSTALLATION**

Installation is self-evident and normal good building practice is assumed during installation. The 60mm service hole can be made in any position along the top plate provided that the hole edge is no closer than 45mm from a stud or nog/dwang. The 60mm hole shall be centred across the top plate to accommodate the pre-punched FFTP. The FFTP shall be fitted to the inside of the frame leaving clean faces to both outside edges of the timber. When being used as a top plate stiffener with top plate packer then Type 17 14g x 75mm hex head screws shall be used.

### **HANDLING**

Prior to use, the FFTP shall be stored in a weatherproof environment and be protected from moisture. Care must be taken to avoid any damage to the surface of the product that may affect the protective galvanised coating.

### **STRUCTURAL INTEGRITY AND STRENGTH**

The installed FFTP will reinstate the top plate or stud to the integrity of the timber prior to the hole being drilled. This is calculated using the verification methods in accordance with the NZBC standards including NZS3603:1993

### **DURABILITY**

The durability of the FFTP is in accordance with the acceptable solutions contained in Table 4.1 of NZS3604:2011 and is intended for use in internal "closed spaces". It is not suitable where this table specifies Stainless Steel.

On behalf of the Design Firm, and subject to:

(i) Site verification of the following design assumptions: The design for the timber frames and timber top plate has been completed in accordance with the relevant building code for the proposed structure, the loading on the structural frame and the performance of these elements is per NZS3604:2011.

(ii) All proprietary products meeting their performance specification requirements.

I believe on reasonable grounds that a) the building, if constructed in accordance with the drawings, specifications, and other documents provided or listed in the attached schedule, will comply with the relevant provisions of the Building Code and that b), the persons who have undertaken the design have the necessary competency to do so.

I Pavneet Sachdeva, CPEng (1027291) am a member of: Engineering New Zealand and hold the following qualifications: B.E.(Civil) MEngSt (Civil) CMEngNZ IntPE. The Design Firm issuing this statement holds a current policy of Professional Indemnity Insurance no less than \$200,000\*.



SIGNED by Pavneet Sachdeva ON BEHALF OF NZ Civil Structure Ltd T/a Prudent Engineers.

Date: 8/04/2024 (VALID TILL 16/04/2025)

Note: This statement shall only be relied upon by the Building Consent Authority named above. Liability under this statement accrues to the Design Firm only. The total maximum amount of damages payable arising from this statement and all other statements provided to the Building Consent Authority in relation to this building work, whether in contract, tort or otherwise (including negligence), is limited to the sum of \$50,000\*.

# Frame Fix Top Plate & Stud Stiffener

## ADVANTAGES:

- Unique design provides greater top plate uplift resistance capacity.
- Quick and easy to install, leaving clean faces to outside edges of the timber frames.
- Comes in one size, designed for use with 90 x 45mm and 140 x 45mm timber only.
- Allows an easy solution to fix penetrations in frames made by other trades.
- PTPS comes complete with fastenings and grommet.
- Timber grade must be SG8 or better.

## INSTALLATION:

- Use Type17 14g x75mm hex head screws when fixing to top plate with top plate packer.
- Use Type17 12g x35mm hex head screws when fixing to single top plate or stud.
- Service hole shall be centred across the timber and the hole to be a maximum of 60mm diameter.
- Service hole can be made in any position along the top plate or stud provided that the hole edge is no closer than 45mm from a stud or nog/dwang.
- FFTP shall be fitted to the inside of the frame to ensure clean outside faces of the timber.
- All screws holes shall be filled.
- Intended for use in internal 'closed spaces' as per Table 4.1 of NZS3604:2011.

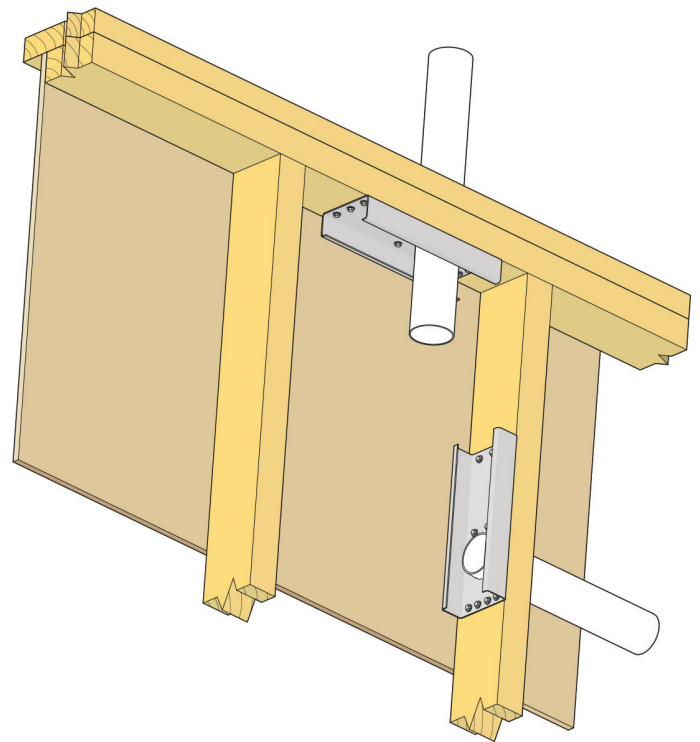

## SPECIFICATIONS

PRODUCT CODE	FFTP or PTPS
MATERIAL	1.6mm G300 Z275 galvanised steel
DURABILITY	Suitable for use in closed environment as per table 4.1 NZS3604:2011
USAGE	Designed to reinstate top plate or stud to FULL STRENGTH after a hole size up to 60mm has been drilled through it.