

## PRODUCER STATEMENT – PS1 – DESIGN

This Design Producer Statement (PS1) is issued by NZ Civil Structure Ltd to Ray Staiger Limited to inform the users of the use and installation method of the following fixings for both structural applications and durability as required by the New Zealand Building Code Clauses B1 & B2 respectively. We have been engaged by Ray Staiger Limited to provide Design services for the following products in respect of the requirements of Clause B1 of the Building Code for Part only of the proposed building work. The design carried out by us has been prepared in accordance with: Compliance Documents issued by the Ministry of Business, Innovation & Employment: B1/VM1.

### PRODUCT CODE AND DESCRIPTION

The product code covered under this Producer statement are following.

- **NPSJ = SimpleFix Nail Plate Stren Joist Stiffener & NPSJD = SimpleFix Nail Plate Stren Joist Stiffener Double**

### PRODUCT DESCRIPTION

The **NPSJ** is manufactured from Z275 1.6mm thick galvanised coil. Each kit contains: 1 x 'U' channel, 2 x arched angles, 1 x 500gm of 3.15 x 30mm nails and 10 (8g x 20mm) screws. (If the hex screw fixing option is used then 30 (12g x 35mm) hex head Type 17 screws are required). The product can be retrofitted after the hole has been cut in the joist.

### PRODUCT APPLICATION

The **NPSJ** & **NPSJD** is intended to reinstate the structural integrity of joist that has suffered service holes after erection. The hole can be made in any position along the span of the joist provided that the hole edge is not closer than one joist depth from the end supports of the joist.

### INSTALLATION

The **NPSJ** and the **NPSJD** retrofit installation is self-evident and normal good building practice is assumed during installation. The **NPSJ** is suitable for all SG8 joist sizes between 140 x 45 to 290 x 45 designed in accordance with NZS3604:2011. The **NPSJD** is suitable for double joists 140 x 90 to 290 x 90 giving the total thickness of 90mm. All nail or screw holes shall be filled.

### HANDLING

Prior to use, the **NPSJ** and **NPSJD** shall be stored in a weatherproof environment and be protected from moisture. Care must be taken to avoid any damage to the surface of the product that may affect the protective galvanised coating.

### STRUCTURAL INTEGRITY AND STRENGTH

The installed Simplefix Stren-Joist will reinstate the strength of a standard joist (specified in accordance with NZS3604:2011) in the vicinity of the service hole and this is calculated using the verification methods in accordance with the NZBC standards including NZS3603:1993. It should be noted that Stren-Joist may not be suitable for penetrations through SED timber beams or double joists.

### DURABILITY

The durability of the **NPSJ** & **NPSJD** is in accordance with the acceptable solutions contained in Table 4.1 of NZS3604:2011 and is intended for use in internal "closed spaces". It is not suitable where this table specifies Stainless Steel.

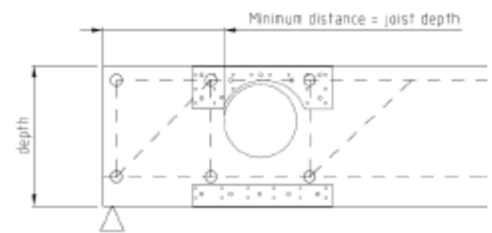

### On behalf of the Design Firm, and subject to:

- Site verification of the following design assumptions: The design for the timber frames and timber top plate has been completed in accordance with the relevant building code for the proposed structure, the loading on the structural frame and the performance of these elements is per NZS3604:2011.
- All proprietary products meeting their performance specification requirements.

I believe on reasonable grounds that a) the building, if constructed in accordance with the drawings, specifications, and other documents provided or listed in the attached schedule, will comply with the relevant provisions of the Building Code and that b), the persons who have undertaken the design have the necessary competency to do so.

I, Pavneet Sachdeva, CPEng (1027291) am a member of: Engineering New Zealand and hold the following qualifications: B.E.(Civil) MEngSt (Civil) CMEngNZ IntPE. The Design Firm issuing this statement holds a current policy of Professional Indemnity Insurance no less than \$200,000\*.



SIGNED by **Pavneet Sachdeva** ON BEHALF OF **NZ Civil Structure Ltd T/a Prudent Engineers**.

Date: 22/05/2026 (VALID TILL 21/05/2027)

Note: This statement shall only be relied upon by the Building Consent Authority named above. Liability under this statement accrues to the Design Firm only. The total maximum amount of damages payable arising from this statement and all other statements provided to the Building Consent Authority in relation to this building work, whether in contract, tort or otherwise (including negligence), is limited to the sum of \$50,000\*.

# Nail Plate Stren Joist

Re-instates integrity of penetrated joists

**FEATURES**

The SimpleFix Stren-Joist has been designed to allow holes to be cut in floor joists to enable pipes, wiring or other services to be passed through the joist. The fitting of a SimpleFix Stren-Joist re-instates the integrity of the penetrated joist.

**INSTALLATION**

1. Use NPSJ to locate and correct vertical location of hole along the joist. Care shall be exercised when installing NPSJ in 140 x 90mm joist where hole location is critical.
2. The hole can be made in any position along the span of the joist provided that the hole edge is no closer than one joist depth from the end supports of the joist. Refer to table for maximum hole size in joist.
3. Present the two angles to either side of hole as shown and nail or screw into place ensuring a tight snug fit onto joist and underside of flooring, use 10 (8g x 20mm) screws for top flange.
4. Present channel to underside of joist and nail or screw into place ensuring a tight and snug fit.

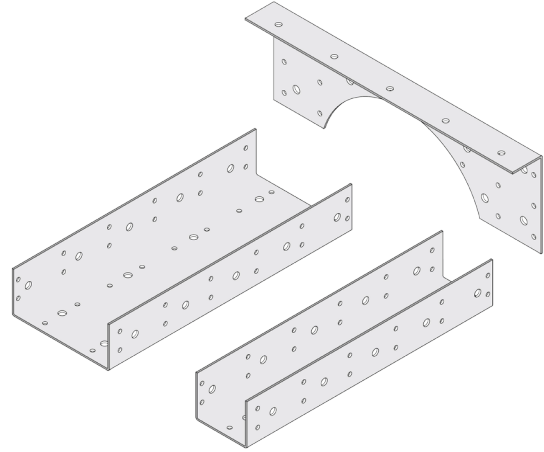

**SPECIFICATIONS**

<b>PRODUCT CODE</b>	NPSJ
<b>MATERIAL</b>	1.6mm G300 Z275 galvanised steel
<b>EACH KIT CONTAINS</b>	1 x 'U' channel (45mm), 2 x arched angles, 80 Product Nails and 10 (8g x 20mm) screws. (If the hex screw fixing option is used then 30 (12g x 35mm) hex head type #17 screws are required.

**SPECIFICATIONS**

<b>PRODUCT CODE</b>	NPSJD
<b>MATERIAL</b>	1.6mm G300 Z275 galvanised steel
<b>EACH KIT CONTAINS</b>	1 x 'U' channel (90mm), 2 x arched angles, 100 Product Nails and 10 (8g x 20mm) screws. (If the hex screw fixing option is used then 34 (12g x 35mm) hex head type #17 screws are required.

**MAXIMUM JOIST PENETRATION (mm)**

	Single Joist Size (mm)	Double Joist Size (mm)	Max Hole Size (mm)
A	140 x 45	140 x 90	72
B	190 x 45	190 x 90	122
C	240 x 45	240 x 90	125
D	290 x 45	290 x 90	125

